

- NOTES:
- 1.- BUTTS SIZE PER APPROVED HDWR. SCHED.
 - 2.- QUANTITY OF BUTTS PER HDWR. SCHED.
 - 3.- HARDWARE LOCATION PER STEELCRAFT.
 - 4.- PROFILE STYLE PER APPROVED DRAWINGS.

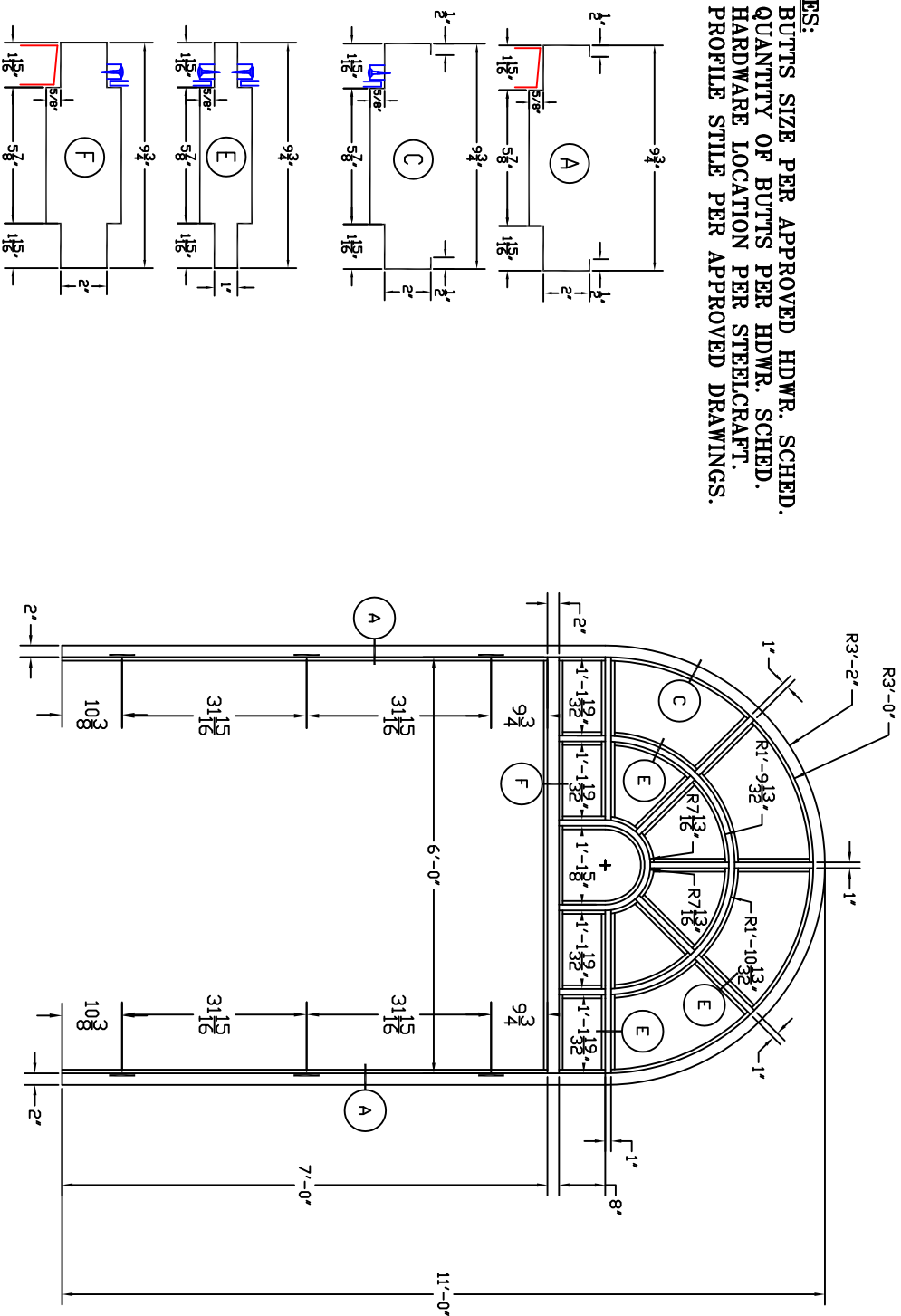

CUSTOMER'S ELEV. 2

PER OUR TERMS AND AGREEMENT RADIUSSED FRAMES HAVE TO BE APPROVED AND SIGNED OFF BY THE AUTHORITIES OF THIS JOB, I.E. ARCHITECT OR CONTRACTOR OR CUSTOMER.

THE AUTHORITIES OF THIS JOB MUST TAKE THE RESPONSIBILITY THAT ALL DIMENSIONS LISTED ARE CORRECT.

MEGAMET WILL PRODUCE THE FRAME AS SUBMITTED (IF APPROVED BY THE AUTHORITIES) IN THIS DRAWING, AND MEGAMET WILL NOT BE HELD RESPONSIBLE IF WE HAVE MIS-INTERPRETED ORIGINAL DRAWING IN ANY WAY.

X _____
 APPROVING AUTHORITY

WE WILL START FABRICATION AS SOON AS WE RECEIVE THIS SIGNED SUBMITTAL.

TOLERANCE ON ALL DIMENSIONS FRACTIONAL \pm 3/32"
 UNLESS OTHERWISE SPECIFIED DECIMAL \pm .00937

CUSTOMER:	
ARCHITECT:	
CONTRACTOR:	

ALL INFORMATION CONTAINED IN THIS DISCLOSURE WHETHER PATENTABLE OR OTHERWISE CONSIDERS PROPRIETARY INFORMATION OF MEGAMET INDUSTRIES, INC. AND ITS UNAUTHORIZED USE OR PUBLICATION WITHOUT THE EXPRESS CONSENT OF MEGAMET INDUSTRIES, INC. IS STRICTLY PROHIBITED.

Manufactured by
MEGAMET INDUSTRIES, INC.
 Birmingham, Alabama

NAME	CORPINTH BAPTIST CHURCH	DRAWN	R. BRADY	DATE	9-28-89		
APPROVED		CHECKED		SCALE			
PROJECT						ELEV 2	REV.